

The logo for the company, featuring the word "DONE" in a bold, teal, sans-serif font. The letter "D" is stylized with a circular element on its left side. The logo is contained within a white rounded square with a thin teal border.

MXG SERIES LED DRIVERS

DL-320W-MXG SPEC V1.1

Features

- Class I structure
 - Input voltage: 120-277 V ~ 50/60 Hz
 - Efficiency :93%(Typ.)
 - Constant power drive and constant current output control mode
 - Metal shell structure, protection grade: IP67
 - Lightning protection level: differential mode 6kV, common mode 15kV
 - Function selection:
- Isolated 3 in 1 dimming
- Lifetime design: 8 years



DL-320W-V56X-MXG



DL-320W-V56T-MXG

Applications

Road lighting、Industrial lighting、Venue lighting
 Floodlight lighting、Landscape lighting、Plant lighting

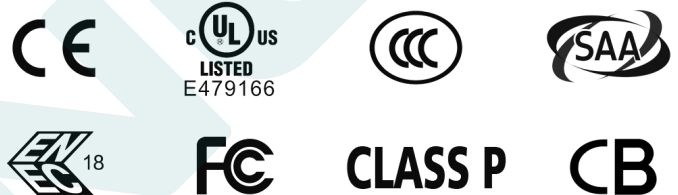

Model list

Model NO.	Input voltage	Output power	Output voltage	The default current	Eff.	T.H.D	PF	NTC
DL-320W-V56X-MXG	120-277V	320W	25-56Vdc	6.8A	≥93%	≤7%	≥0.97	
DL-320W-V56T-MXG	50/60Hz							√

- Note :**
1. Test conditions of the above parameters: Ta=25℃, 230Vac input, full load operation for 30 minutes;
 2. When the input is less than 108Vac,the output power gradually decreases to 50% ± 10%.When the input 120-277VAC,rated power 320W.Please refer to “THE OUTPUT POWER VS INPUT VOLTAGE” curve chart for details.
 3. DL-320W-V56T-MXG supports the external NTC function. When the temperature of the indicator board rises to a preset threshold, the power output decreases. 10K, BK3350-3399 is recommended for external NTC, Murate NCP18XH103J03RB is recommended (setting required temperature parameters by off-line programming).

Input characteristics

Parameter	Min	Typ.	Max	Note
Rated input voltage	120Vac	230Vac	277Vac	
Input voltage range	90Vac		305Vac	
Rated frequency	47Hz	50/60Hz	63Hz	
Power factor	-	0.97	-	@230Vac full load
T.H.D.	-	-	7%	@230Vac full load
Input current	-	-	3A	@120Vac full load
Inrush current	-	-	70A	230Vac, cold start (25°C)

Output characteristic

Parameter	Min	Typ.	Max	Note
Rated current				
DL-320W-V56X-MXG	-	5.7A	-	
DL-320W-V56T-MXG				
Output current range				
DL-320W-V56X-MXG	4.2A	-	7.65A	
DL-320W-V56T-MXG				
Output voltage range				
DL-320W-V56X-MXG	25V	-	56V	
DL-320W-V56T-MXG				
Rated power(90-120Vac)	-	160W	320W	The derating begins when the input voltage is less than 108 ± 10%Vac
Rated power(120-277Vac)	-	320W	-	
No-load voltage				
DL-320W-V56X-MXG	-	-	63V	
DL-320W-V56T-MXG				
Efficiency@120Vac				
DL-320W-V56X-MXG	91.4%	92.3%	-	full load
DL-320W-V56T-MXG				

Output characteristic

Parameter	Min	Typ.	Max	Note
Efficiency@230Vac DL-320W-V56X-MXG DL-320W-V56T-MXG	-	93%	-	full load
Accuracy of output current	-3%	-	+3%	
output ripple current	-	5% maximum current	-	100% load 20MHZ band Wide ripple current = RMS / The average
Line regulation	-3%	-	+3%	
Load regulation	-3%	-	+3%	
Starting time		-	1000ms	Full load@120Vac
		-	500ms	Full load@230Vac

Note: The output current range is limited by the input and output voltage, please refer to "I-V WORKING AREA" for details.

Dimming characteristic

Dimming function		Min	Typ.	Max	Instructions
0-10V Dimming (Optional)	Safe applied voltage range	0V	-	12V	When the external voltage is $\geq 12V$, the dimming will fail
	Dimming output range	0	-	100%	-
	Rated dimming voltage range	0V	-	10V	It can be set to negative dimming mode through program setting
PWM Dimming (Optional)	PWM high level	9.5V	-	10.5V	-
	PWM low level	0V	-	0.3V	-
	PWM frequency band	300Hz	-	2000Hz	-
	PWM duty cycle	0	-	99%	Output full power at 99% duty cycle
Resistor Dimming (Optional)	External resistance value	0K Ω	-	100K Ω	-
	Dimming output range	0	-	100%	-

Note:

- Output current of dimming port: 108 μ A (typical value);
- The maximum withstand voltage of the dimming port is 12V. If the external power supply voltage exceeds 12V or the signal line is reversely connected, the power supply will be damaged.

Protection

Function	Function instructions
Input under-voltage protection	When the input voltage is less than 108Vac, the output power decreases to 50%±10%.
Output overload protection	Protection mode:hiccup mode,recovers automatically after fault condition is removed.
Output short circuit protection	Hiccup mode:recovers automatically after fault condition is removed
Over temperature protection	Self-recovery type: when the housing temperature is greater than 90℃, the output power decreases to 50%±10%.
Output over-voltage protection	Protection mode: Hiccup mode or clamped in output highest voltage , the product is not damaged, LED driver works normally after fault condition is removed.

Note:

1. Unless otherwise specified, all specifications and parameters shall be measured at the conditions of 230Vac (50Hz), rated load and 25℃ of ambient temperature;
2. Including setting error, line regulation and load regulation.

Environmental

Environmental categories	Parameter
Working temperature	-40 ~ +60℃@200-277Vac, -40 ~ +45℃ @120-200Vac (refer to "Life Curve ")
Working humidity	20 ~ 95% RH, non condensing
Maximum Tc temperature	Tc=+90℃
Storage temperature, humidity	-40~+85℃, 10 ~ 95% RH
Resistant to vibration	10 ~ 500Hz, 5G 12 min/cycle, X, Y, Z axis 72 min each
MTBF	230Khrs min. MIL-HDBK-217F (Ta=25℃)
Lifetime	70000 h @ housing temperature ≤75 ° c, 230Vac, 80% load, see section "housing temperature and life"

Safety and EMC

Safety categories	Standard
Safety	GB19510.1、GB19510.14、EN61347-1、EN61347-2-13、IEC61347-1、IEC61347-2-13、AS/NZS61347.1、AS61347.2.13 UL8750;
EMC	EN 55015、EN 61547、EN 61000-3-2、GB/T 17743、GB17625.1、EN 61000-3-3 FCC Part 15
Surge protection	Differential mode L-N $\pm 6\text{KV}$ (2 ohm) ,common mode L, N-PE $\pm 15\text{KV}$ (12 ohm); Refer to IEC61000-4-5 2014 Criterion B
High-pot test	I/P-O/P:3.75KVac I/P-PE :1.5KVac O/P-PE : 0.5KVac I/P-DIM:3.75KVac O/P-DIM:1.5KVac
Insulation impedance	I/P-PE:100M Ω / 500VDC; I/P-O/P:100M Ω / 500VDC / 25 $^{\circ}\text{C}$ / 70% RH
Leakage current	<0.7mA@277Vac

Note:

- 1.The driver is considered as a component that will be operated in combination with the final equipment. Since EMC performance will be affected by the complete installation,the final equipment manufacturers must re-qualify EMC Directive on the complete installation again.

I-V Working area

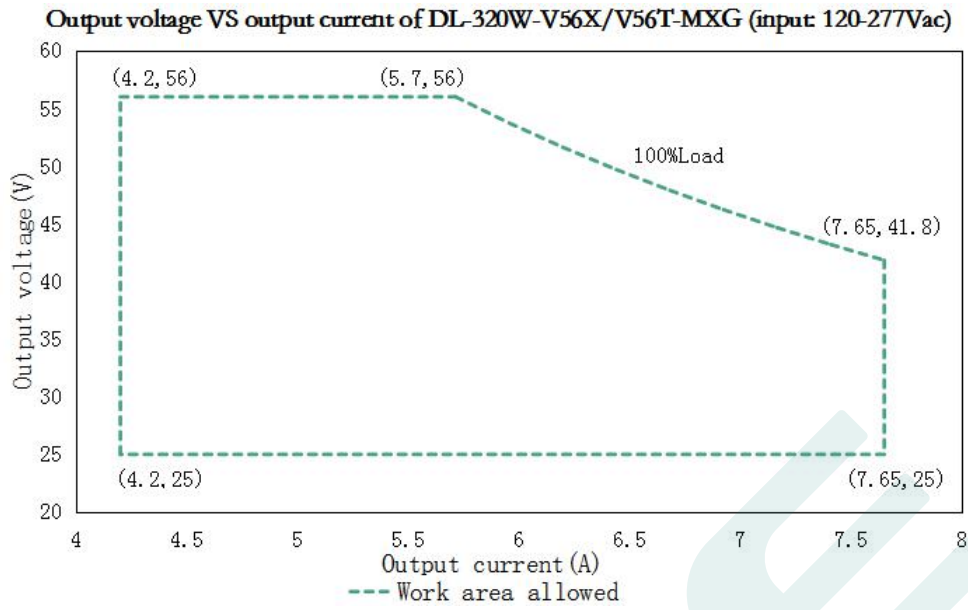

Load	Output								
Load working Voltage	25V	29V	33V	37V	42V	45V	48V	52V	56V
Io_MAX	7.65A	7.65A	7.65A	7.65A	7.62A	7.1A	6.7A	6.2A	5.7A
Po_MAX	191.3W	221.9W	252.5W	283.1W	320W	320W	320W	320W	320W

Eff. VS Output voltage(DL-320W-V56X/V56T-MXG)

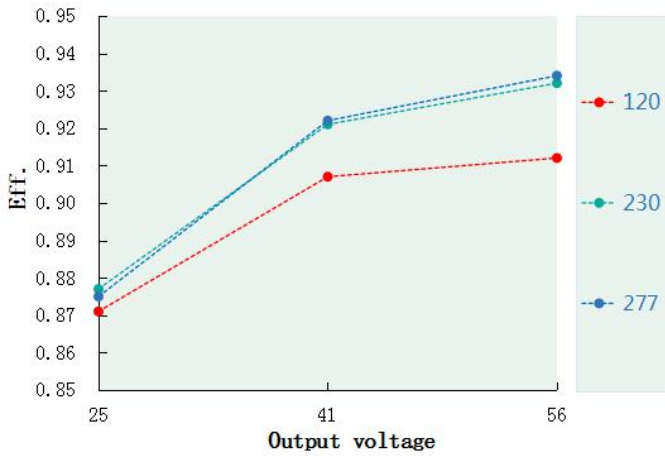

Power factor VS Input voltage(DL-320W-V56X/V56T-MXG)

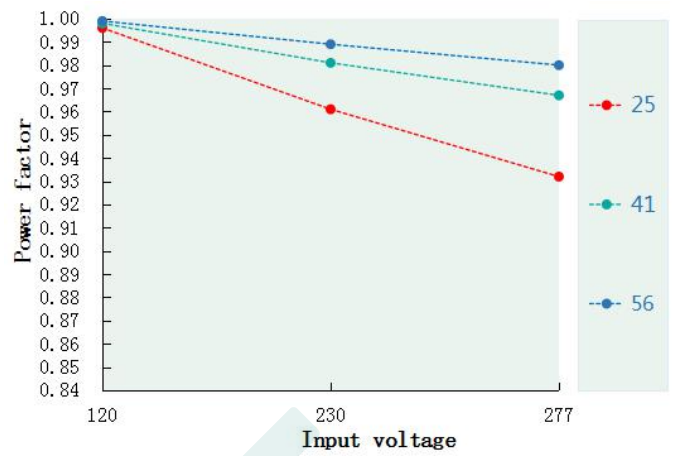

T.H.D. VS Output voltage(DL-320W-V56X/V56T-MXG)

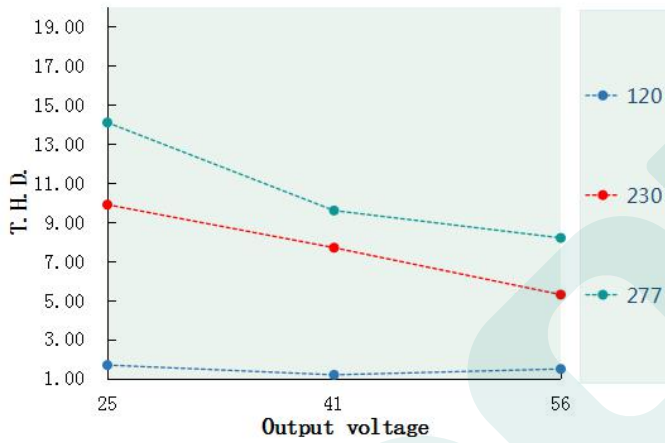

Tcase VS Lifetime(DL-320W-V56X/V56T-MXG)

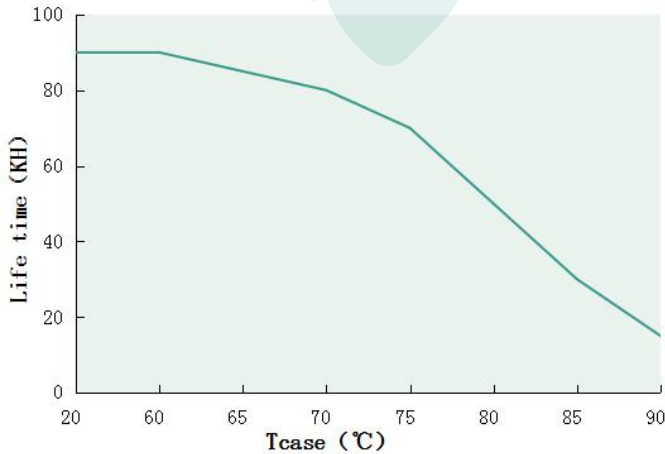

Output power VS Tcase (DL-320W-V56X/V56T-MXG)

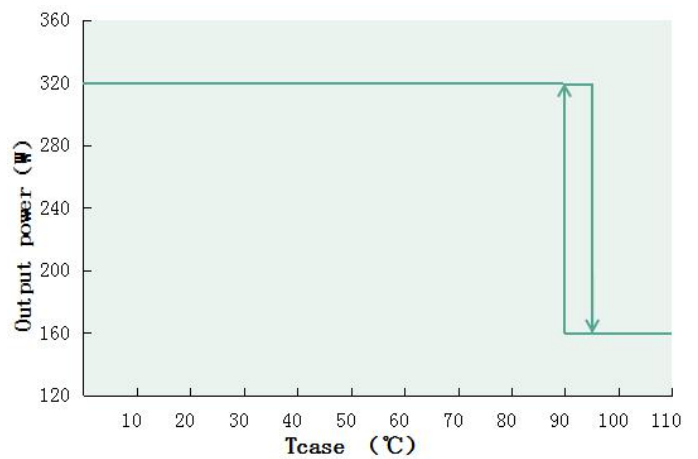

Output power VS Input voltage

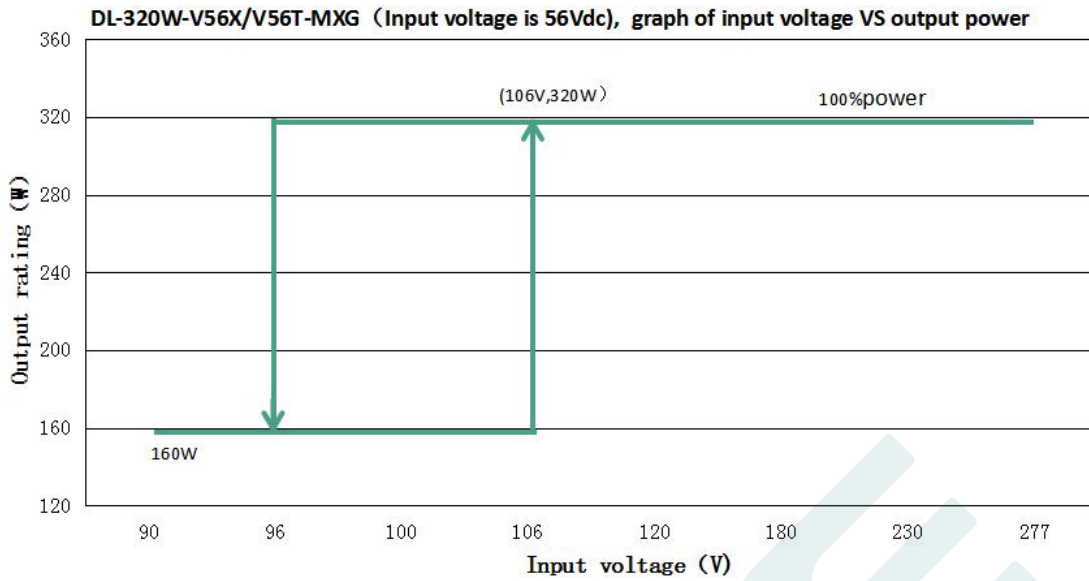

DL-320W-V56X/V56T-MXG (When the output voltage is 56Vdc, the rated output current value and output power corresponding to different input voltage)

Input Voltage	90Vac	95Vac	100Vac	106Vac	120Vac	180Vac	230Vac	277Vac
Iout	2.86A	2.86A	2.86A	5.7A	5.7A	5.7A	5.7A	5.7A
Pout	160W	160W	160W	320W	320W	320W	320W	320W

- Note:**
- 1.Input voltage will fluctuate, resistance error and other factors. At the decrease or increase of power ($V_{in}=108V_{ac}$), it will move left and right, with the range of $108V \pm 10\%$.
 2. When the input voltage is 90-106Vac, the output power range is $160W \pm 10\%$.

Dimming operation

※ Three-in-one dimming function (X version)

- A. connect a resistor 0-100K or 0-10V DC voltage or 10V PWM signal between DIM+ and DIM- to adjust the output current.
- B. output current of dimming port: 108uA (typical value). (to be determined!)

◎ With an applied voltage of 0-10V:

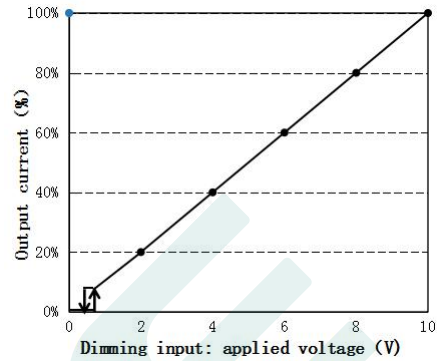
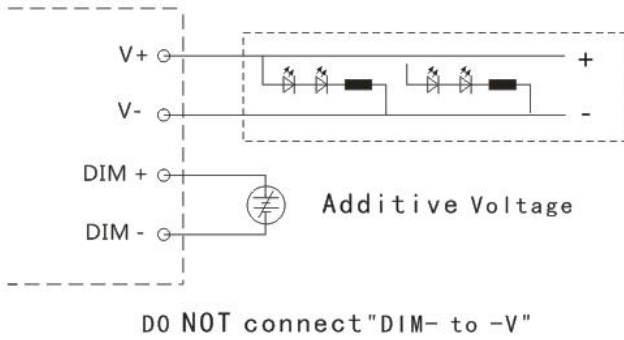

◎ Applying additive 10V PWM signal (Frequency range: 300Hz-2K Hz) :

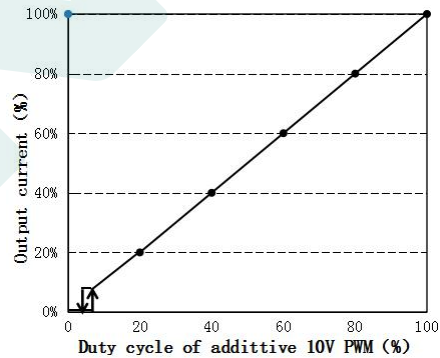
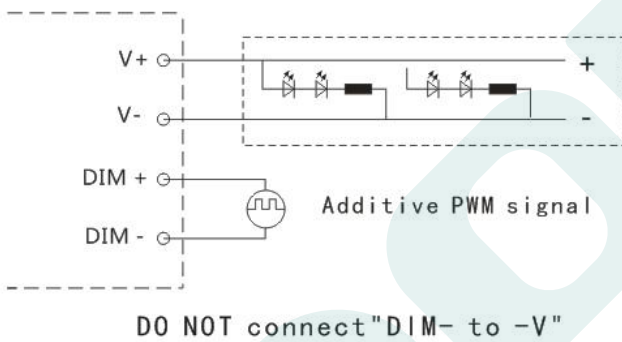

◎ With an additional 0-100K resistor:

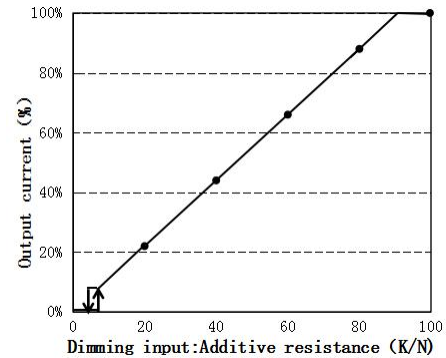
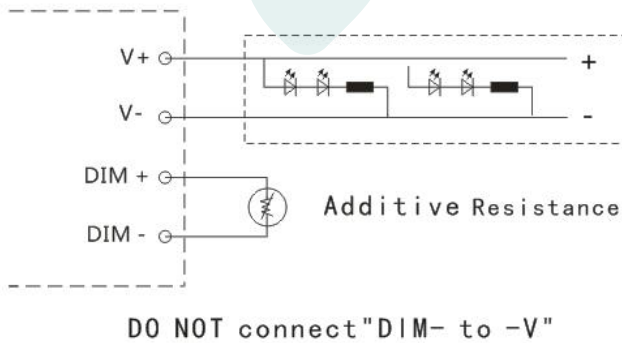

Mechanical specification

Size (mm) L244mm*W83mm*H40mm

DL-320W-V56X-MXG



DL-320W-V56T-MXG

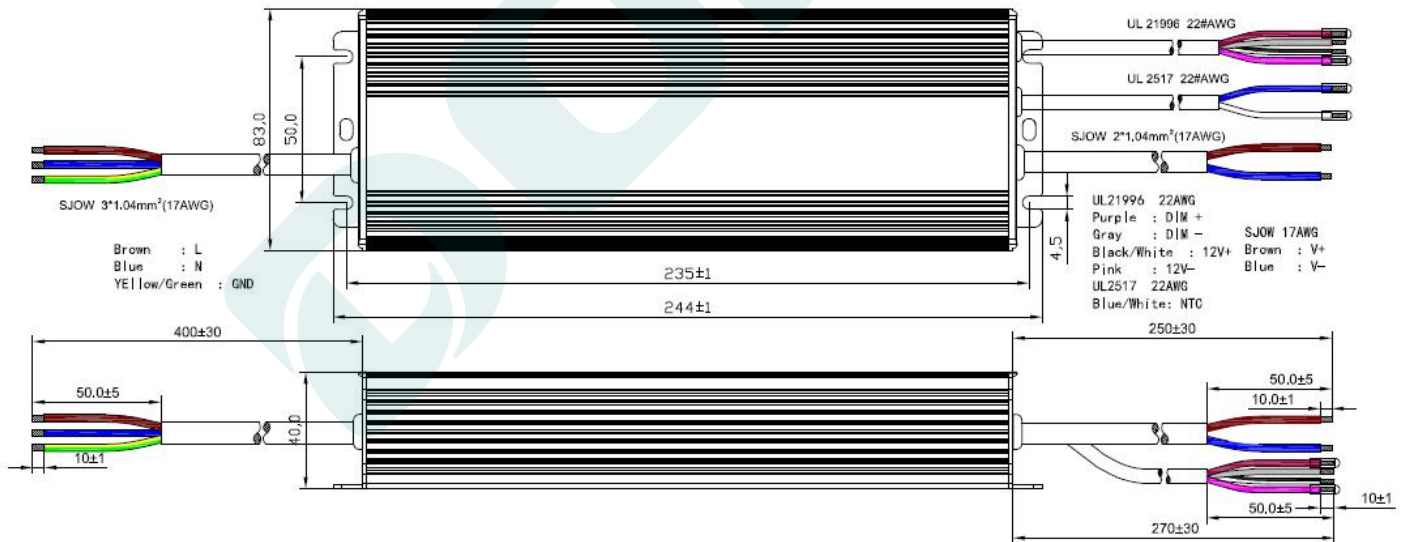

Weight

Weight 1530 g

Packaging

Packaging (mm) L475*W350*H160

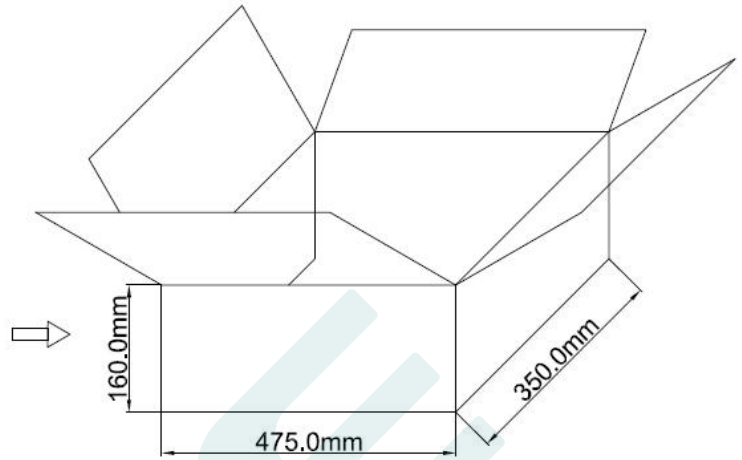
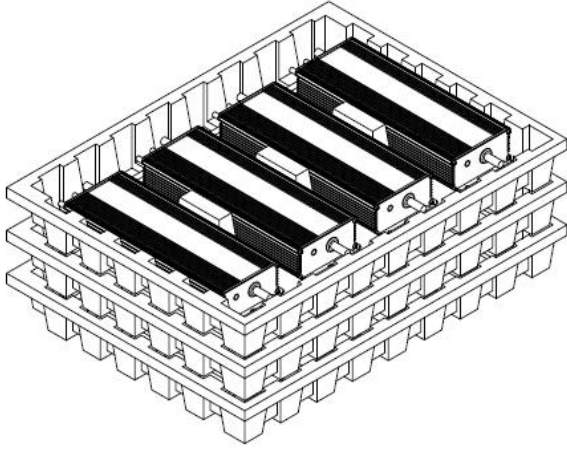

Note: One Carton 3 layers and 4 pcs each layer, total 12pcs/carton.

Note:

1. According to the certificate obtained by the LED DRIVER, the LED DRIVER with the English label is sold in Europe, America and India.
2. The LED DRIVER with Chinese label is only used for China market.

Version

DATE	DESCRIPTION	REV.	CHECK
2021.9.13	Initial version.	V1.0	
2021.11.20	1.Page 4, increase the output ripple current; 2.Page 5, add the description of maximum casing temperature; 3.Page 5, instructions for increasing life span; 4.Page 10,Update the resistance dimming ratio graph .	V1.1	

MANUFACTRUER

EDIT	CHECK	APPROVE
